



# YARD FORCE®

LAWN & GARDEN EQUIPMENT

**LM G46D**

**Y0JZ-SP02-4640**

**GB**

## **40V CORDLESS LAWNMOWER**

**Original Instructions**

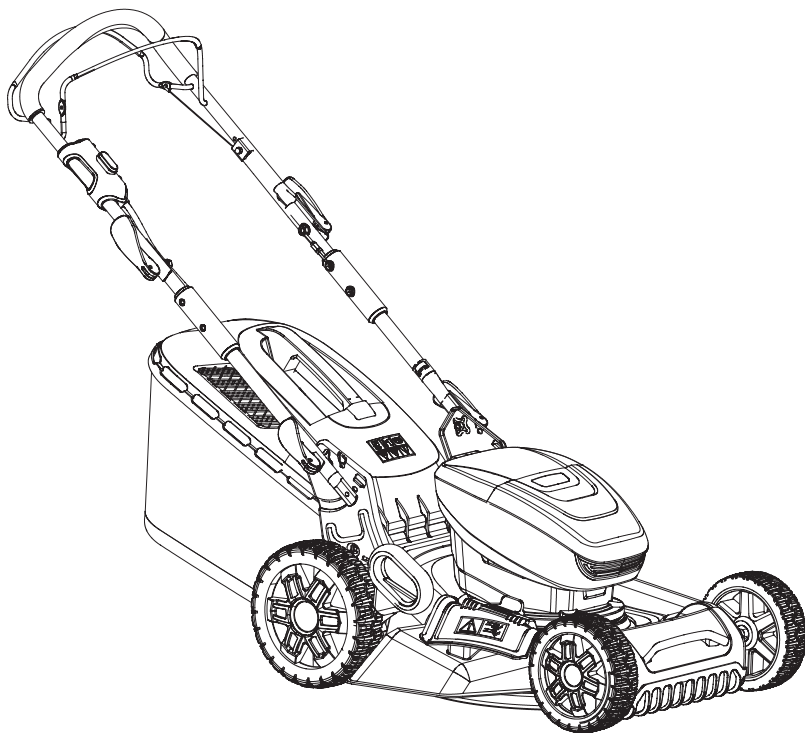

**READ & UNDERSTAND  
INSTRUCTION MANUAL**

**Save all warnings and instructions for future reference.**



Read this manual carefully prior to assembling and operating the lawnmower. It is dangerous to operate this product without being familiar with these instructions. Keep this manual in a safe place and have it ready for future reference.

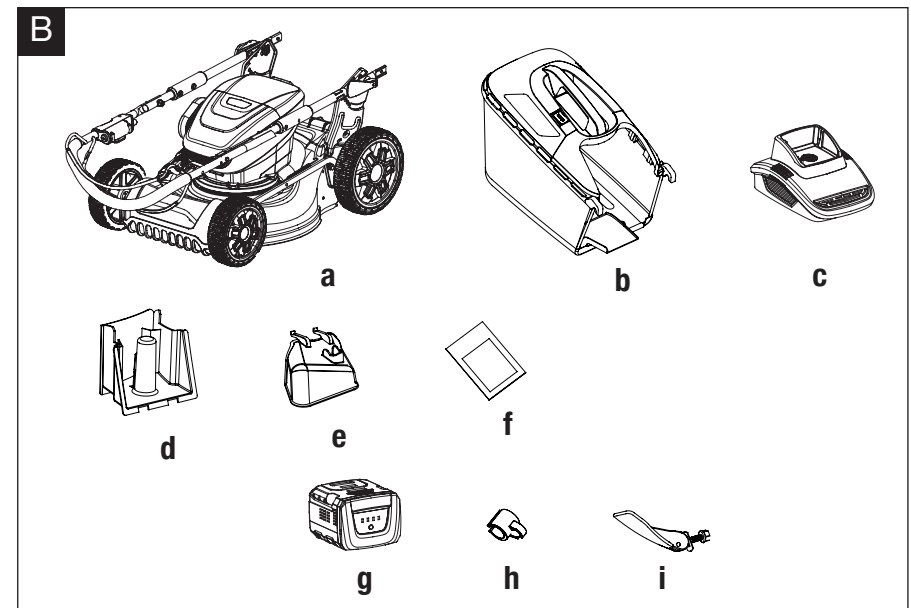
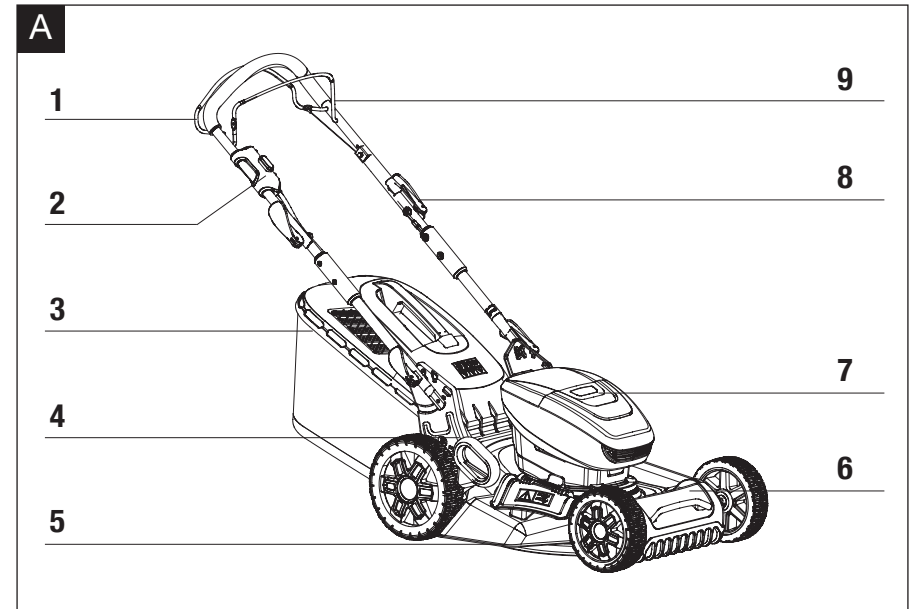

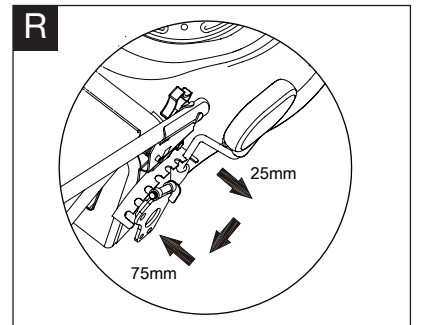
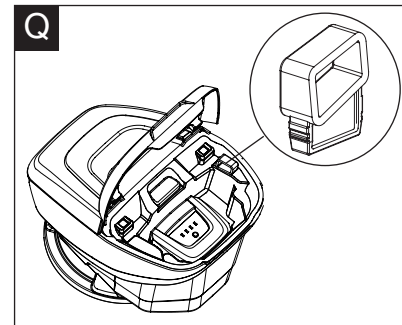
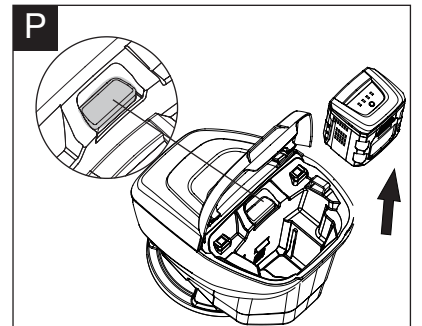
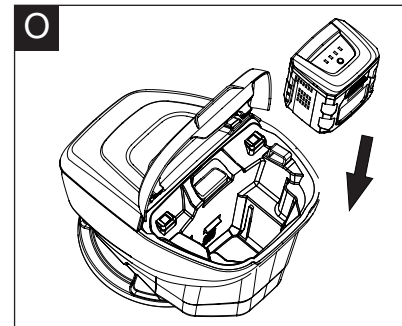
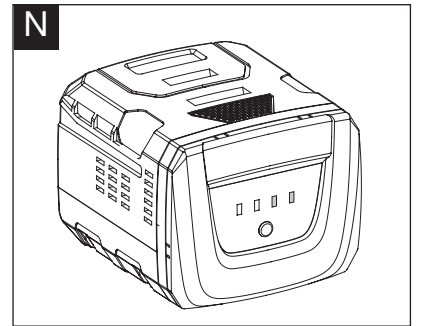
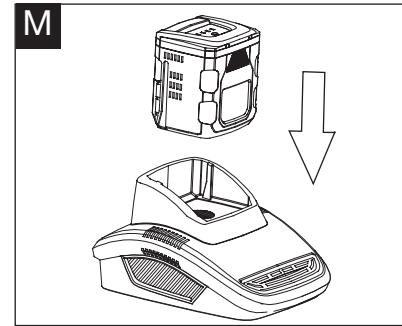
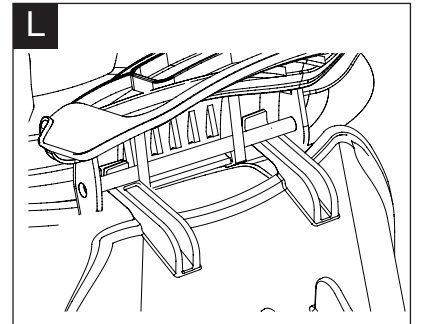
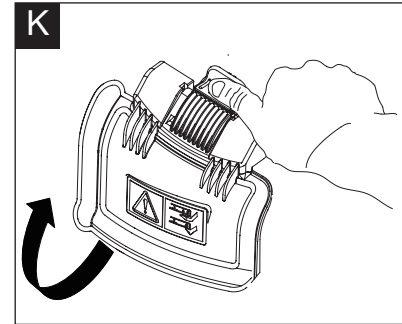
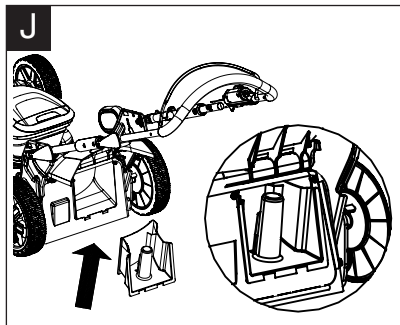
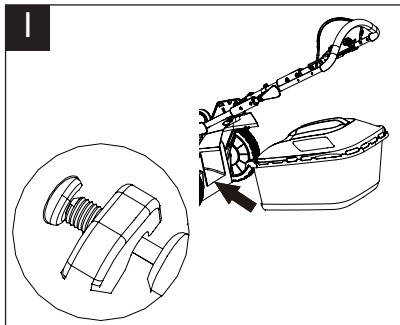
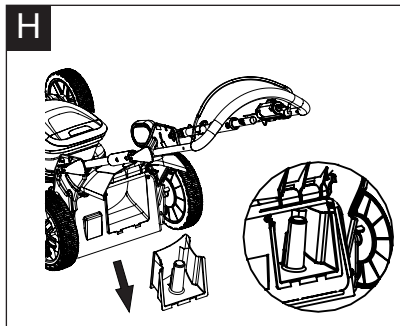
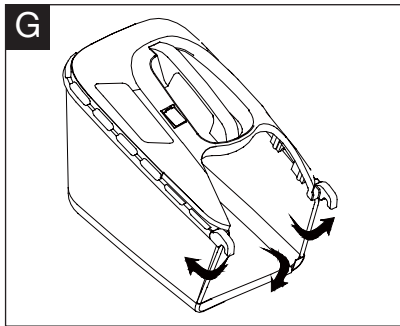
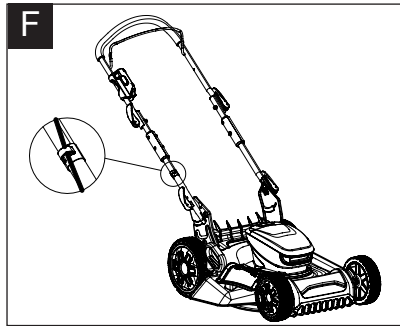
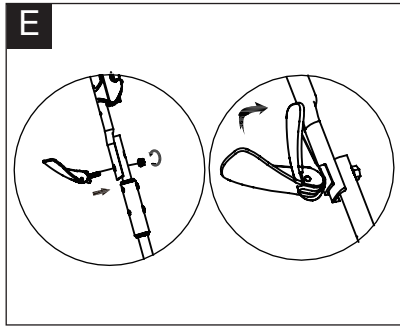
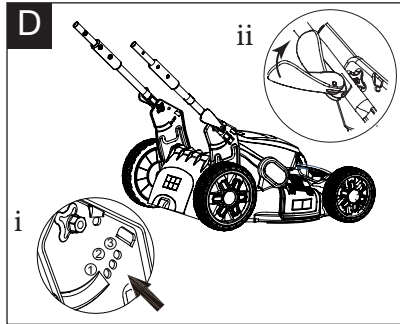
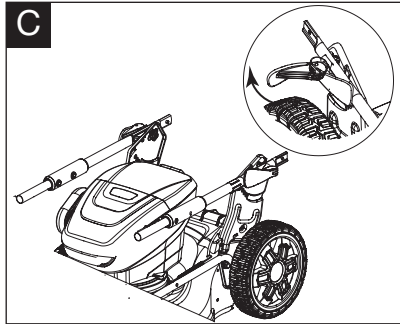

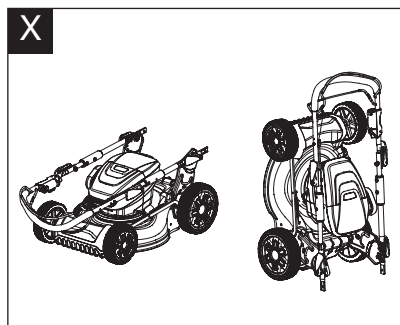
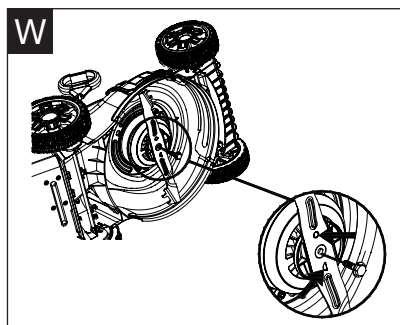
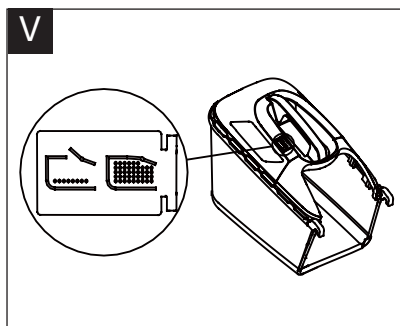
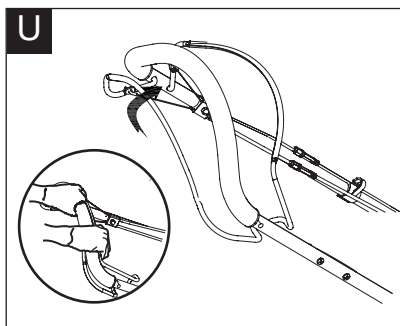
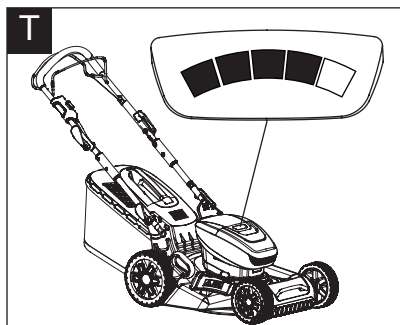
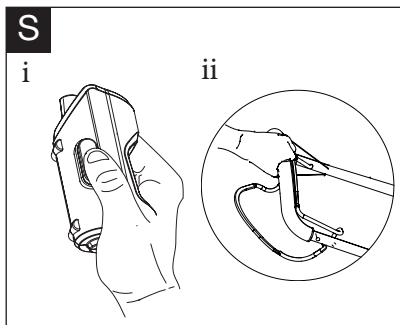

# YARD FORCE

## LM G46D Original Instruction

### CONTENT

Intended use	08
General safety warnings	08
Product safety warnings	10
Symbols	16
Technical data	20
Description of product	21
Installation	22
Operation	23
Maintenance and storage	26
Troubleshooting	28
CE declaration	29

## INTENDED USE

This lawnmower has been designed for cutting grass. The machine is to be used only for its prescribed purpose, any other use is deemed to be a case of misuse.

Please note that our equipment has not been designed for use in commercial, trade or industrial applications. Our warranty will be voided if the machine is used in commercial, trade or industrial businesses or for equivalent purposes.

## GENERAL SAFETY WARNINGS



**WARNING:** Read all safety warnings and instructions. Failure to follow the warnings and instructions may result in electric shock, fire and/or serious personal injury.

Carefully read the instructions for the safe operation of this machine.

Save all warnings and instructions for future reference.

- This appliance can not be used by children and persons with reduced physical, sensory or mental capabilities or lack of experience and knowledge if they have been given supervision or instruction concerning the use of the appliance in a safe way and understand the hazards involved.
- Children should be supervised to ensure that they do not play with the product.

**IMPORTANT  
READ CAREFULLY BEFORE USE  
KEEP FOR FUTURE REFERENCE**

## GENERAL SAFETY WARNINGS

### Training

1. Read the instructions carefully and make sure you fully understand them. Make sure you are familiar with the controls and the correct use of the product.
2. Never allow small children or people unfamiliar with these instructions to use the product. Local regulations can restrict the age of the operator.
3. Never operate the product while people, especially children or pets are nearby.
4. Keep in mind that the operator or user is responsible for any accidents or hazards occurring to other people or their property.

### Preparation

1. While operating the product always wear substantial footwear and long trousers. Do not operate this product when barefoot or wearing open sandals. Avoid wearing clothing that is loose fitting or has hanging cords or ties.
2. Thoroughly inspect the area where the product is to be used and remove all objects which could be thrown by the product.
3. Before use, always visually inspect to see that the blade, blade bolt and the blade assembly are not worn or damaged. Replace worn or damaged components in sets to preserve balance. Replace any damaged or unreadable labels.
4. Ensure the switch is in the off position before inserting the battery pack. Inserting the battery pack into a machine that is switched on can result in injury.

## PRODUCT SAFETY WARNINGS

### General Operation

1. Use the tool only with specifically designated battery packs. Use of any other battery packs will increase the risk of injury and fire.
2. Only operate the product in daylight or in good artificial light.
3. Do not expose tool and charger to rain or wet conditions. If a tool or charger is exposed to moisture it will increase the risk of electric shock.
4. Avoid operating the product on wet grass.
5. Always be sure of your footing on slopes.
6. Walk, never run.
7. Mow across the face of slopes, never up and down.
8. Exercise extreme caution when changing direction on slopes.
9. Do not mow excessively steep slopes.
10. Use extreme caution when reversing or pulling the product towards you.
11. Stop the blades if the product has to be tilted for transportation, when crossing surfaces other than grass and when transporting the product to and from the area to be mowed.
12. Never operate the product with defective guards or shields or without safety devices in place such as deflectors or grass collector.
13. When switching on motor keep feet well away from blades.
14. Do not tilt the product when switching on the motor, except if the product has to be tilted for starting. In

## PRODUCT SAFETY WARNINGS

- this case, do not tilt it more than absolutely necessary and lift only the part furthest away from the operator.
15. Do not start the product when standing in front of the discharge opening.
  16. Do not put hands or feet near or under rotating parts.
  17. Keep clear of the discharge opening at all times.
  18. Do not transport the product while the cutting blade is running.
  19. Stop the product and remove the key/battery pack from the machine and make sure that all moving parts have come to a complete stop:
    - Whenever you leave the product unattended.
    - Before clearing blockages or unclogging chute.
    - Before checking, cleaning or working on the product.
    - After striking a foreign object. Make sure to inspect the product for damage and make repairs before restarting and operating the product.
  20. If the product starts to vibrate abnormally:
    - Inspect for any damages.
    - Replace or repair any damaged parts.
    - Check for and tighten any loose parts.

### Charger

1. Recharge only with the charger specified by the manufacturer. Do not use the original charger on other li-ion batteries or on any other type of battery as this can increase the risk of fire or explosion.

## PRODUCT SAFETY WARNINGS

2. Check the battery charger, cable and plug before each use. Do not use the battery charger if damaged. Do not open the battery charger yourself; charger must be repaired by qualified personnel using original spare parts.
3. The charger is designed to use a standard household 220-240 V~ 50Hz power source, ensure that the plug matches the outlet.
4. Never modify the plug in any way, this will reduce the risk of electric shock.
5. Do not abuse the cord of charger. Never use the cord for carrying, pulling or unplugging the charger. Keep cord away from heat, oil, sharp edges or moving parts. Damaged or entangled cords increase the risk of electric shock.
6. Make sure the charger cord is situated so that it will not be stepped on, tripped over or get damaged.
7. Keep the battery charger clean. Contamination can increase the risk of electric shock.
8. Protect the battery charger from rain and moisture. If water accesses the battery charger there is an increased risk of electric shock.
9. Battery will heat up whilst charging. To reduce the risk of fire, do not operate battery charger on flammable surfaces such as paper or textiles.
10. The temperature range over which the battery pack can be charged is typically between 5°C-45 °C. Attempts to charge out with the prescribed temperature range may automatically be blocked by

## PRODUCT SAFETY WARNINGS

- the protection circuitry of the battery pack. Longest life and best performance can be obtained if the battery pack is charged at room temperature.
11. Disconnect charger from the power supply when not in use. This will reduce the risk of electric shock or damage to the charger.

### Battery pack

1. Fully charge battery pack before first use.
2. Recharge battery pack immediately when the power output starts to slow. **DO NOT CONTINUE TO USE PRODUCT WHEN BATTERY LEVEL IS LOW.**
3. To prevent serious damage to the battery, charge in temperatures above 5°C or below 45°C. Longest life and best performance can be achieved when battery is charged at room temperature.
4. If the battery temperature is above 45°C it must be allowed to cool before putting it into the charging station.
5. To reduce the risk of explosion, ensure the battery pack is not left in the sun for extended periods of time and that it is kept away from fire.
6. Do not carry individual battery packs in your pockets or bag as they could short-circuit against other metal items.
7. Should a li-ion battery catch fire, ensure to use the correct fire extinguisher to combat the fire. **DO NOT THROW WATER ON A BURNING LI-ION BATTERY.**

## PRODUCT SAFETY WARNINGS

8. If the battery pack becomes too hot during charging, disconnect and switch off immediately. Contact the service centre directly.
9. Do not attempt to open the battery yourself.
10. When battery pack is not in use keep it away from other metal objects such as paperclips, coins, keys, nails, screws or other small metal objects that can make a connection from one terminal to another.

## Maintenance and storage

1. Keep all nuts, bolts and screws tight to be sure the product is in a safe working condition.
2. Check the grass collector frequently for wear or deterioration.
3. Be careful when adjusting the product to prevent trapping fingers between moving blades or other fixed parts of the product.
4. Always allow the product to cool down before storing.
5. When servicing the blades be aware that even though the power source is switched off, the blades can still move.
6. Replace worn or damaged parts for safety. Use only genuine replacement parts and accessories.
7. DO NOT attempt to open the charger and battery pack. There are no customer serviceable parts inside. Return to any authorised service centre.
8. Store the appliance with battery pack fully charged at room temperature (around 20°C).

## PRODUCT SAFETY WARNINGS

9. Every deep discharge cycle decreases the capacity of battery pack. To prolong battery life, it is recommended that you charge the battery every six months within extended periods of time when the product is not in use.

## Servicing

1. Have your tool repaired by an authorised service agent. This tool is manufactured in accordance with the relevant safety regulations. To avoid danger, equipment must only be repaired by qualified technicians.
2. Only use parts and accessories made for this machine by the manufacturer. Failure to do so can result in personal injury.

## SYMBOLS

### Safety symbols

The purpose of safety symbols is to attract your attention to any possible dangers. The safety symbols and their explanations deserve your careful attention and full understanding. The symbol warnings do not, by themselves, eliminate any danger. The instructions and warnings they give are no substitute for proper accident prevention measures.

 **WARNING:** Be sure to read and understand all safety instructions within this operator's manual, including all safety alert symbols such as "**DANGER**", "**WARNING**", and "**CAUTION**" before using this tool. Failure to follow all instructions listed below may result in electric shock, fire and/or serious personal injury.

**SAFETY ALERT SYMBOLS:** Indicate **DANGER**, **WARNING**, or **CAUTION**. May be used in conjunction with other symbols or pictographs.

### Symbol meanings

This page depicts and describes safety symbols that may appear on this product. Read, fully understand and follow all instructions on the machine before attempting to assemble and operate.

## SYMBOLS



To reduce the risk of injury, user must read instruction manual carefully.



Avoid using tool in the rain. Wait until all machine components have completely stopped before touching them.



Keep bystanders away. Objects thrown by the product could hit the user or other bystanders. Always ensure that other people and pets remain at a safe distance from the product when it is in operation.



Beware of sharp blades. Blades continue to rotate after the motor is switched off. Remove disabling device before performing any maintenance tasks.



Guaranteed sound power level value is 96 dB



Wear ear protection, eye protection when using the product.



## SYMBOLS



WEEE symbol. Waste electrical products should not be disposed of with household waste. Please recycle where facilities exist. Check with your local authority or local store for recycling guidelines



The product complies with the applicable European directives and an evaluation method of conformity for these directives was done.

### Warning symbols on the battery pack



To reduce the risk of injury, user must read instruction manual carefully.



Do not throw into water.



Do not throw on fire.



Do not subject the battery to strong sunlight over long periods of time. Do not leave on a heater (max.45°C).



Li-Ion

Batteries contain Li-ion. Do not dispose of waste batteries in domestic waste. Contact local authority to find out how to dispose of batteries.



The product complies with the applicable European directives and an evaluation method of conformity for these directives was done.

## SYMBOLS



WEEE symbol. Waste electrical products should not be disposed of with household waste. Please recycle where facilities exist. Check with your Local Authority or local store for recycling advice.

### Warning symbols on the charger



To reduce the risk of injury, user must read instruction manual carefully.



The charger is for indoor use only.



Double insulation

T3.15A



Protective 3.15 A limited







WEEE symbol. Waste electrical products should not be disposed of with household waste. Please recycle where facilities exist. Check with your Local Authority or local store for recycling advice.



The product complies with the applicable European directives and an evaluation method of conformity for these directives was done.

## TECHNICAL DATA

<b>Mower Type</b>		<b>LM G46D</b>
Nominal voltage of product with battery		40 V $\text{---}$ / 5 Ah
No-load cutting speed		3300 min <sup>-1</sup>
Cutting width		46 cm
Cutting height		25-75mm, 7 Positionen
Capacity of grass bag		60 l
Weight		27.3 kg
Measured sound power level(L <sub>WA</sub> )		90 dB(A), K=3 dB(A)
Guaranteed sound power level		96 dB(A)
Vibrations		1.85 m/s <sup>2</sup> K=1,5 m/s <sup>2</sup>
<b>Battery pack Model</b>		<b>B0P-SP04-4050ZB</b>
Battery capacity		40V $\text{---}$ 5Ah
Battery charging time		100 min
<b>Battery charger Model</b>		<b>B0Q-SP03-4030ZA</b>
Input		220-240 V $\sim$ , 50/60 Hz 160 W
Output		40 V $\text{---}$ ,3A
Protection class		II

The sound values have been determined according to noise test code given in EN 60335-2-77, using the basic standards EN ISO 11201 and EN ISO 3744.

The sound intensity level for the operator may exceed 80 dB(A) and ear protection measures are necessary.

The declared vibration value has been measured in accordance with a standard test method (according to EN 60335-2-77) and may be used for comparing one product with another. The declared vibration value may also be used in a preliminary assessment of exposure.



**WARNING:** Depending on the actual use of the product the vibration values can differ from the declared total!  
Adopt proper measures to protect yourself against vibration exposure! Take the whole work process including times the product is running under no load or switched off into consideration!

## DESCRIPTION OF PRODUCT

### Parts description (Fig. A)

1. Self-propelled switch lever
2. Safety button
3. Grass bag
4. Cutting height adjustment lever
5. Side discharge chute
6. Front carry handle
7. Power head
8. Quick release clamp
9. Start / stop lever

### Check the delivery parts (Fig. B)

Remove the machine from its packaging carefully and make sure that all of the following parts are present:

- a. Lawnmower with upper handle
- b. Grass bag
- c. Charger
- d. Mulching plug
- e. Side discharge chute
- f. Manual
- g. battery pack
- h. Cable clip
- i. Quick release clamp



**WARNING:** If any parts are damaged or missing, do not operate this tool until these parts have been replaced. Failure to heed this warning could result in serious personal injury.



**NOTE:** Always recycle the packaging in accordance with local recycling guidelines.

## INSTALLATION

### Unfold the handle

1. Rotate the handle quick release levers to release the operation handle (Both sides). (Fig. C)
2. Rotate the handle and then position the lower handle lock pin into the mower bracket - one of the three angle positions (Both sides). (Fig. D)
3. Lock the handle in place by closing the handle quick release levers- make sure that the handle is securely locked in position (Both sides).

### Attach the top handle to the lawnmower (Fig. E)

Mount the top handle to the lower handle by using two quick release clamps (screw with curved head)

### Fitting the cable clip (Fig. F)

Ensure that the cable clips supplied are used to fix the cable to the lower handle

### Attach the grass bag

Attach the grass bag to the frame by fixing the plastic hooks onto the side (Fig. G)

Lift the safety flap with one hand and hook in the grass bag. Release the ejector flap to secure the grass bag in position. (Fig. H&I)

**NOTE:** Make sure the mulching plug is not in the rear chute of deck.

### Installing the mulching plug (Fig. J)

**NOTE:** Switch off the tool and make sure that the blade has stopped completely.

1. Lift the rear flap with one hand and push the mulching plug into the rear discharge chute until it is locked in place. Make sure that the mulching plug is locked in position.
2. Release the rear safety flap, it will close back to cover the mulching plug.

### Installing the side discharge chute

1. Lift the side discharge cover with one hand and hook in the side discharge chute with the other hand. (Fig. K)
2. Release the side discharge cover to secure the chute in position. (Fig. L)

### Set required function

**WARNING!** Before changing any accessory, switch off the tool and make sure that the blade has stopped completely

**NOTE:** This lawnmower has three functions. These functions can be converted by changing accessory setting as described above. Please see the following chart for detail.

	Mulching plug	Grass collection bag	Side discharge chute
Collection	×	√	×
Mulching	√	×	×
Side Discharge	√	×	√

“√”: installed “×”: uninstalled

## OPERATION

### Charging the battery pack (Fig. M)

**NOTE:** Remove the battery pack from the charger after it has been fully charged.

**NOTE:** Battery should be fully charged before first use.

**NOTE:** Make sure the mains voltage is the same as rating label which is located on the charger.

1. Connect the charger to a power supply. The red LED will light up.
2. To insert the battery pack into the charger, align the raised ribs of the battery pack with the grooves of the charger then push it in.
3. The green LED light of the charger will flash continuously during normal charging.
4. After charging is complete, the green LED will light up.

### Power indicator (Fig. N)

This Li-Ion battery pack is equipped with a power indicator which is used to show the battery pack's remaining charge. Press the power indicator button to check battery charge as below. The LEDs will stay lit for approximately 4 seconds.

### To obtain the best life from the battery

1. Never allow the battery to completely discharge before recharging. The battery pack should be placed on the charger whenever the battery pack is noticeably running down or the tool no longer performs a task it previously performed.
2. Avoid conducting short charges. Make sure that the battery is fully charged each time by allowing the charger to complete its full charging cycle.
3. Avoid allowing loose items like screws or nails etc. to be stored with battery packs as these or similar items can short battery packs and cause a fire or explosion
4. Always unplug the charger when not in use and store in a dry and secure place.
5. Avoid charging or storing your battery in temperatures below 5°C and above 45°C.
6. After use, allow the battery to pack to cool down for approximately 30 minutes before attempting to recharge.

### Removing and inserting the battery pack

#### Insert the battery pack. (Fig. O)

Align the battery pack with its compartment of the tool. Push the battery pack into the tank until you hear a click. This means the battery pack has been locked in position, then close the battery pack tank cover.

#### Removing the battery pack from the tool (Fig. P)

Open the battery pack tank cover. Push the battery pack release button, the battery pack will come out automatically.

#### **NOTE: Safety-Key (Fig. Q)**

This lawnmower is fitted with a safety key; this prevents the accidental start up of your cordless lawnmower. The safety key has been designed to totally disable the lawnmower when it is removed.

## OPERATION

### Setting cutting height (Fig. R)

If you wish to change the cutting height, push the adjusting lever first to make it out of the tooth and then push the lever to the desired position.



**WARNING:** Never operate the adjusting handle roughly.

### Switching on and off (Fig. S)

#### Switch on:

1. Press and hold the safety button on the side of the switch box with one hand.
2. Pull the switch bar towards the handle and hold it with the other hand.

#### Switch off:

Release the switch bar.

**NOTE:** During the normal operation, the five indicators on the power head will shine accordingly to show the remaining capacity of battery pack. (Fig. T)

### Using the drive function (Fig. U)

This unit is self-propelled.

1. Start the mower as previously mentioned.
2. Use one hand to hold the blade control bar firmly pressed against the main handle.
3. Use your free hand to press the drive control bar towards the main handle, and grip the main handle with both hands. The drive system will engage immediately.
4. Release the drive control bar to disengage the drive system. Releasing the blade control bar will stop the engine; this will also stop the drive system.



#### WARNING:

When the motor has been switched off, the blade will continue to run for several seconds. Do not touch the underside of the mower until the cutter has come to a complete standstill!

### Operating the lawnmower

#### Operation on a slope:

Slopes increase the risk of slip-and-fall accidents, which can result in severe injury. Always be sure of your footing on slopes. Operation on slopes requires extra caution. If you feel uneasy on a slope, do not mow it.

#### Do:

- Mow across the face of slopes, never mow up and down. Exercise extreme caution when changing direction on slopes.
- Watch for holes, ruts, rocks, hidden objects or bumps which could cause you to slip or trip. Tall grass can hide obstacles.

#### Do not:

- Do not mow near drop-offs, ditches or embankments; you could lose your footing or balance.
- Do not mow slopes greater than 15 degrees.
- Do not mow on wet grass. Unstable footing could cause you to slip.

## OPERATION

### Mower overload protection

To prevent overload conditions, do not try to cut too much grass at one time. Slow down your cutting pace or raise the cut height. Your mower has built-in overload circuit protection. When the mower is overloaded, the motor will stop. Switch the mower off and check to see if grass has collected beneath the deck and clear it if necessary, then restart the mower.

### Battery high temperature protection

The battery pack will generate heat during operation. The heat dissipates slower in hot weather. If the battery temperature exceeds more than 70 °C during operation, the protection circuit will immediately turn off the mower to protect the battery pack from damage. Release the bail handle, wait until the battery pack cools down and then restart the mower.

### Function of full indicator (Fig. V)

If the grass bag is empty or it is not filled with grass, the grass full indicator will be open. If the grass bag is filled with grass the grass full indicator will be closed.

### Emptying the grass bag

As soon as the grass bag indicator closes while you are mowing this means that it is time to empty the grass bag.

**NOTE:** Before taking off the grass bag, switch off the engine and wait until the blade has come to a complete stop.

To take off the grass bag, use one hand to lift up safety flap and the other to grab onto the carry handle. The safety flap automatically falls down after removing the grass bag and closes off the rear chute opening.

Empty out the grass bag then refit to machine.

**NOTE:** If any grass residue is caught in the discharge chute, clean it using a brush. Do not remove grass debris in the mower casing or on the blade by hand or with your feet. Instead use suitable tools such as a brush or broom. To ensure that the cut grass can be collected into grass bag, the discharge opening and inside the mower casing must be cleared of any blockages.

## MAINTENANCE AND STORAGE



**WARNING:** Before performing any maintenance or cleaning work, always ensure that the battery pack/safety key has been removed. Wait until the blade has stopped completely and the machine has cooled down.

### Cleaning

#### Cleaning the product

- Use a soft brush to remove accumulated dust and debris. Wear safety glasses to protect your eyes whilst cleaning.
- Wipe down the product enclosure with a slightly damp cloth. Do not spray the unit with water. Water may destroy the switch unit and the electric motor.

### Maintenance

**NOTE:** Always wear gardening gloves when handling or working near sharp blades.

1. Keep all nuts, bolts and screws tight to ensure that the machine is in a safe working condition.
2. Check the grass bag frequently for wear or deterioration.
3. Examine the machine and replace worn or damaged parts for safety.

#### Removing/Installing the blade (Fig. W)

1. Use the correct size wrench to uninstall the blade bolt nut.
2. Wearing heavy gloves hold the blade still and turn the wrench anti-clockwise to remove the bolt.
3. Fit the replacement blade correctly with marking facing up and align pegs, refit the bolt and retighten securely to torque 20N.m.



**WARNING:** Replace or re-sharpen the mowing blade at the end of the mowing season. Always have the mowing blade re-sharpened or replaced by a recommended Yard Force service centre. Unbalanced blades will cause the lawn mower to vibrate violently which can increase the risk of accidents occurring.

#### Battery maintenance:

Use the following procedures to achieve the best battery life:

1. Protect the battery against moisture and water.
2. Store the battery only within temperature range of 5 °C to 45 °C. Do not leave the battery in direct sunlight for extended periods of time.
3. Clean the battery regularly with a soft, clean and dry brush.
4. If you do not use the product for a long time, remember to charge and discharge the battery pack once every 6 months.

## MAINTENANCE AND STORAGE

### Storage and transport

#### Storage

After cleaning the unit thoroughly, store mower in a dry room and allow the motor to cool down.

To reduce storage space the lawnmower can be folded. **(Fig. X)**

1. Loose the quick release lock system on handles.
2. Fold the handles.
3. Store.

**NOTE:** Remove the safety key and battery packs. Ensure cables are not trapped when folding/unfolding the handle. If stored vertically make sure the mower is positioned in a corner so that the blade is facing inwards against a wall and the machine is secure to prevent it falling over.

#### Transport

Use the original packaging to ship whenever possible.

## TROUBLESHOOTING



**WARNING:** Before performing any repair work, always ensure that the battery pack has been removed.



**WARNING:** Always wear heavy duty gloves when adjusting or cleaning, especially when handling sharp objects.

Fault/malfunction	Cause	Remedy
Mower fails to start	Safety key is not inserted	Insert safety key
	Battery is not correctly inserted	Remove the battery and reinsert
	Mower standing in high grass	Start motor on shorter grass or already mowed area, change cutting height if necessary
	The mower housing is clogged	Clean housing so that the blade can move freely
	Battery has no power	Check and recharge battery
Mower stops working /loses power	Cutting height is incorrect	Adjust the cutting height
	Cutting blade is worn or damaged	Replace with new blade from dealer service centre
Grass bag is not filled sufficiently	Battery performance decreasing	Check the battery performance and charge it if necessary
	Cutting height is too Low	Adjust and increase cutting height
	The lawn / grass is wet	Allow the lawn to dry
	Underside of the mower deck is clogged.	Clean the underside of the mower deck
Mower vibrating at higher speed	Cutting blade is worn or damaged.	Replace it by contacting the customer service centre
	Cutting blade is unbalanced	Balance the blade by grinding each cutting edge until equal
Mower cuts unevenly	Blade is Loosened /incorrectly fitted	Tighten the blade bolt
	The blade is damaged Blade is assembled incorrectly	Sharpen the blade or replace Re-assemble blade correctly

## CE DECLARATION

To the provisions of Council Directives

We  
**SUMEC UK**

**Unit A&B Escrick Business Park Escrick, York YO19 6 FD/ United Kingdom**

**Declare that the product:**

Machine Description: 40V CORDLESS LAWNMOWER

LM G46D/ YOJZ-SP02-4640

Function: Cutting grass

**Complies with the essential health and safety requirements of the following directives:**

Machinery Directive 2006/42/EC

Electromagnetic Compatibility Directive 2014/30/EU

EC Directive 2011/65/EU and its amendment Directive (EU) 2015/863 (RoHS)

We additionally confirm the following in accordance with the 2000/14/EC amended by

2005/88/EC emissions guideline,

Measured Sound Power Level ( $L_{WA}$ ): 90 dB(A), K=3 dB(A)

Declared Guaranteed Sound Power Level: 96 dB (A)

TÜV Rheinland LGA Products GmbH - Tillystraße 2 -90431 Nürnberg

Notified under No. 0197

**Standards and technical specification referred to :**

EN 60335-1:2012+A11+A13+A1+A14+A2

EN 60335-2-7:2010

EN 62233:2008

EN ISO 3744:1995

ISO 11094:1991

EN 55014-1:2017

EN 55014-2:2015

EN 50581:2012

Authorized Signatory

Date: 24.03.2020

Signature: \_\_\_\_\_

Place: York

Name: Mariana Hall

General Manager

SUMEC UK

Unit A&B Escrick Business Park Escrick

York YO19 6 FD, United Kingdom

## CE DECLARATION

To the provisions of Council Directives

We  
**SUMEC France Sarl**  
**59 bis Rue du Mûrier**  
**37540 Saint Cyr Sur Loire**  
**France**

**Declare that the product:**

Machine Description: 40V CORDLESS LAWNMOWER

LM G46D/ Y0JZ-SP02-4640

Function: Cutting grass

**Complies with the essential health and safety requirements of the following directives:**

Machinery Directive 2006/42/EC

Electromagnetic Compatibility Directive 2014/30/EU

EC Directive 2011/65/EU and its amendment Directive (EU) 2015/863 (RoHS)

We additionally confirm the following in accordance with the 2000/14/EC amended by

2005/88/EC emissions guideline,

Measured Sound Power Level ( $L_{wA}$ ): 90 dB(A), K=3 dB(A)

Declared Guaranteed Sound Power Level: 96 dB (A)

TÜV Rheinland LGA Products GmbH - Tillystraße 2 -90431 Nürnberg

Notified under No. 0197

**Standards and technical specification referred to :**

EN 60335-1:2012+A11+A13+A1+A14+A2

EN 60335-2-7:2010

EN 62233:2008

EN ISO 3744:1995

ISO 11094:1991

EN 55014-1:2017

EN 55014-2:2015

EN 50581:2012

Authorized Signatory

Date: 24.03.2020



Signature: \_\_\_\_\_

Place: Saint Cyr Sur Loire

Name: Rodolphe Dubois

General Manager

SUMEC France Sarl

59 bis Rue du Mûrier, 37540 Saint Cyr Sur Loire, France

